

Major	Signature	Date

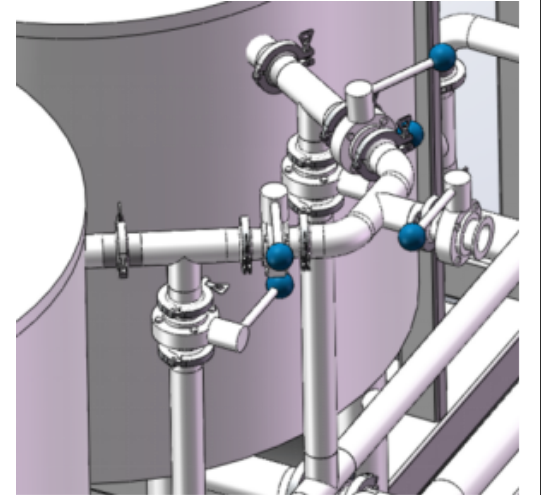
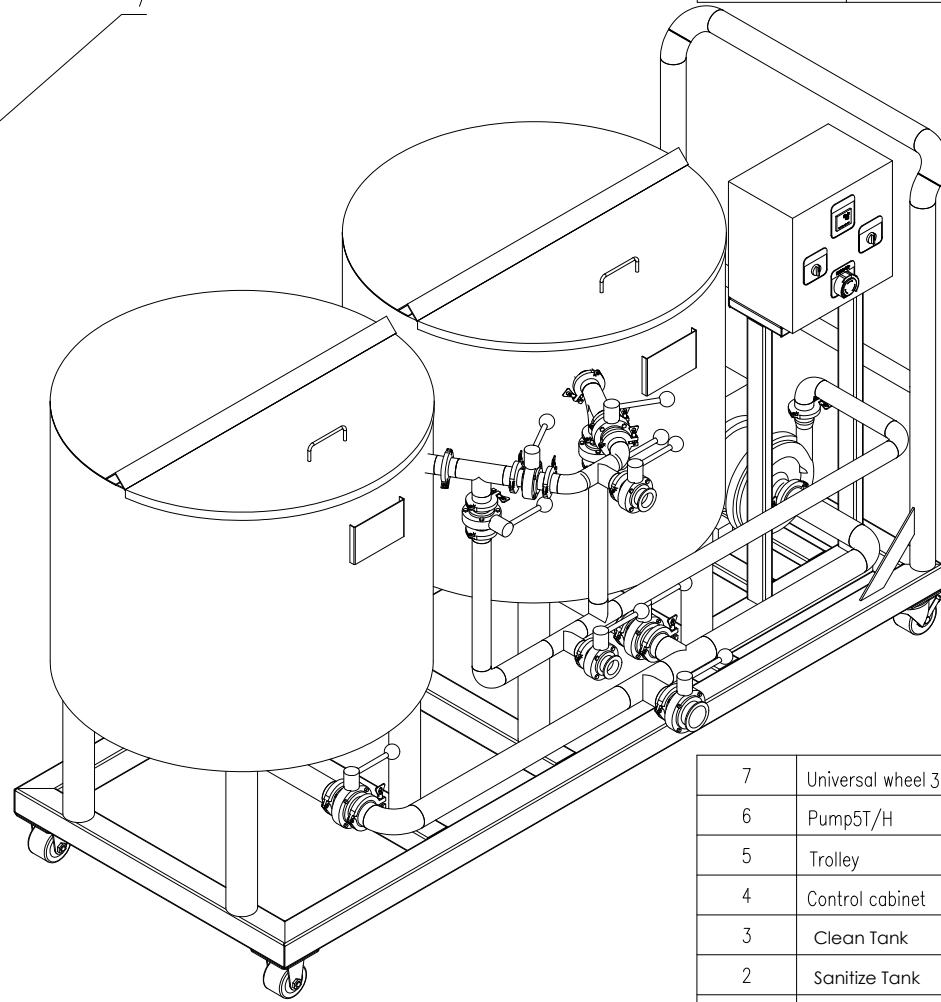
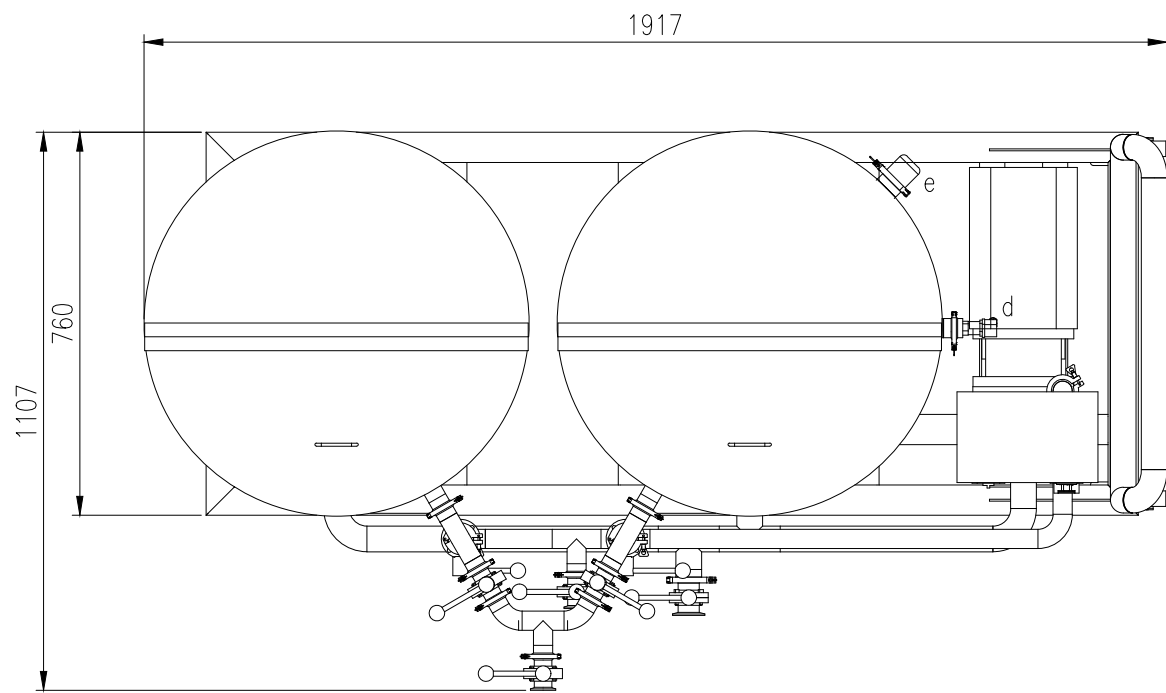
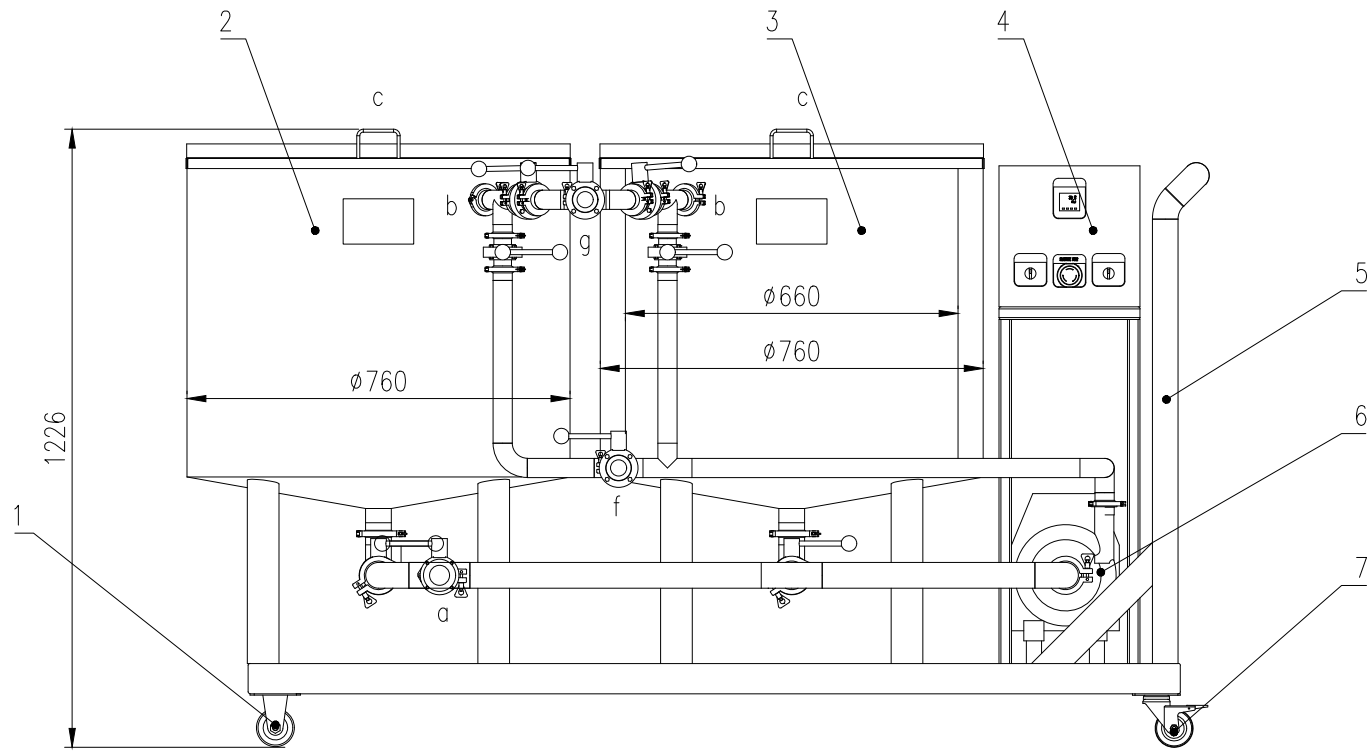

		Pipe / Port		
Mark	Size	Face Type	Description	Notes
a	ø38	Tri-clamp	Drain Outlet	
b	ø32	Tri-clamp	Intlet	
c			Manual open top lid	
d	ø38	Tri-clamp	Thermowell Sensor	
e	ø51	Tri-clamp	Heating element	
f	ø32	Tri-clamp	Outlet	
g	ø32	Tri-clamp		
Clean Tank total Volume		L	230	
Sanitize Tank total Volume		L	280	
Anti corrosion Coating	The stainless steel inner surface of the equipment is treated with pickling and passivation, and the outer surface is brushed with stainless steel to remove oil stains by tearing off the film, and coated with stainless steel special maintenance oil			
Technical requirement	1. all pipeline fittings are made of 304 stainless steel. 2. Throw 60mm fine sand strip at the weld seam. 3. The equipment uses TIG welding.			

7	Universal wheel 3"	2	Combination			
6	Pump5T/H	1	Combination			
5	Trolley	1	S30408			
4	Control cabinet	1	Combination			
3	Clean Tank	1	S30408			
2	Sanitize Tank	1	S30408			
1	Directional wheel 3"	2	Combination			
NO.	Description	Qty	Material	Single Weight (kg)	Total Weight (kg)	Remarks
Name				Area		
200L CIP				Design Project		FS
				Design Stage		P&ID
				NO. :		
Scale	1:15	Date	2026.6.25	Version	A	Pages Page